

Referans Nr.	d	L	b	b1	m	sw	Sıkma Verileri Tightening Data		
							Nm	kN	
1670-12130 1670-12160	M12	130 160	65 90	24	14	14	120	63	160 185
1670-14130 1670-14160	M14	130 160	65 90	28	15	15	191	86	216 246
1670-16140 1670-16160	M16	140 160	70 95	32	16	17	302	118	310 340
1670-18150 1670-18180	M18	150 180	70 95	35	19	19	405	144	395 450
1670-20150 1670-20180	M20	150 180	70 95	40	22	22	580	184	520 575
1670-22150 1670-22180	M22	150 180	70 95	40	22	24	772	228	610 705
1670-24170 1670-24205 1670-24250	M24	170 205 250	75 105 140	47	22	27	994	265	875 990 1125
1670-30250 1670-30315	M30	250 315	135 195	55	32	36	1930	421	1950 2260

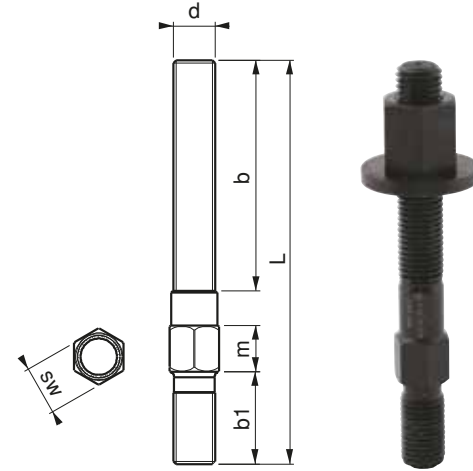

Ürün Nr. 1670 Anahtar Ağızlı Saplama

- Kullanım alanı; Enjeksiyon makinelerinde ve M12-14-16-18-20-22-24-30 diş açılmış pleytlerde kullanılır.
- Kalite 10.9
- Siyah kaplama

Product Nr. 1670 Wrench Mouth Stud

- Area of Use: This stud is used in injection machines and in plates with M12-14-16-18-20-22-24-30 threads
- Quality 10.9
- Black coating

Not: 150 °C üzerindeki ortamlarda sıkma işlemi yapılırken dişlerin üzerine Loctite 8150 kullanılır.

Note: Environments on the 150 °C when clamping action on the thread Loctite 8150 is used.



Loctite
8150

